



ANALOG PHONE, WEATHER PROOF
DESK AND BULKHEAD

ORDERING INFORMATION

DYNALEC PART

ANALOG PHONE 65032-300



FEATURES:

- Designed to interface with any PBX utilizing a standard two wire analog interface
- Weather proof phone designed to meet stresses common to sea-going vessels such as shock, vibration and EMI.
- Responds to forward party disconnect signaling.
- Operates with H-319/U handset, H-320/U headset, LS-613A/STC-1 or LS-614/STC-1 intercoms.
- Features automatic redial button and 10 speed dials.
- LED backlit dial pad for night time use.
- A sonalert is provided for audible signaling and a LED for active indication.
- Supports PTT operation.
- Enclosure is of cast aluminum construction and is designed for desk or bulkhead mounting.

RELATED EQUIPMENT

EQUIPMENT	NOMENCLATURE
Handset	H-319/U
Headset	H-320/U
Intercom Station	LS-613A/STC-1
Handsfree Intercom Station	LS-614A/STC-1

WEATHER PROOF, ANALOG PHONE

DESIGN SPECIFICATIONS

Input Voltage	48 VDC \pm 5%
Input Power	5 Watts Max 10 Watts Max with LS-614A/STC-1
Weight	8.5 lbs (3.9 Kg)
Shipping Weight	9.5 lbs (4.3 Kg)

MOUNTING INFORMATION

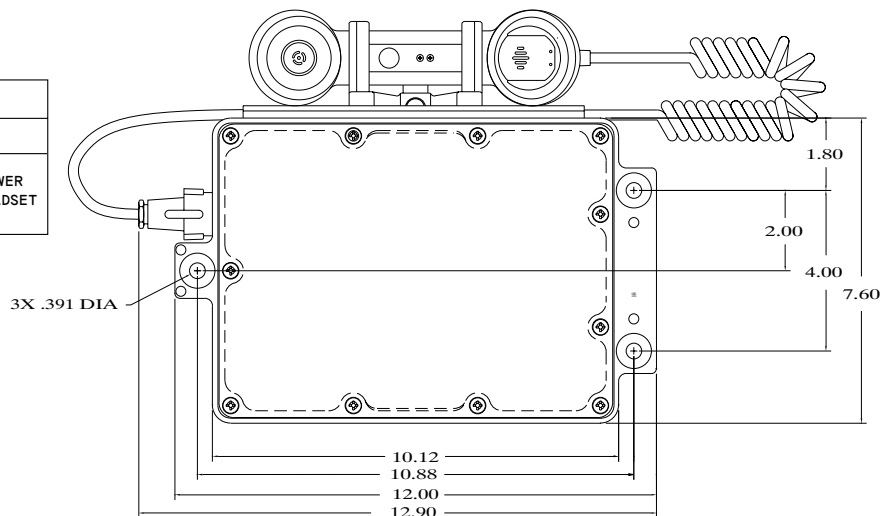
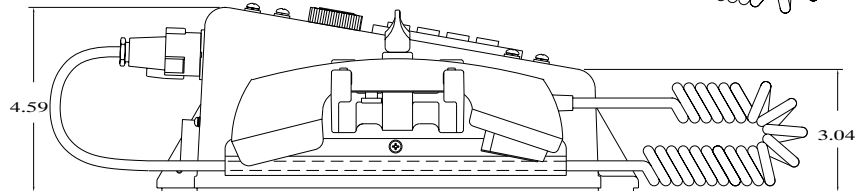
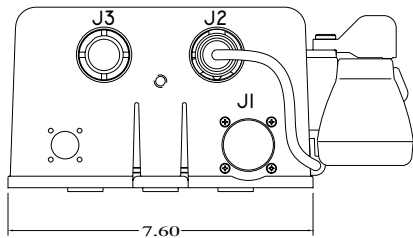
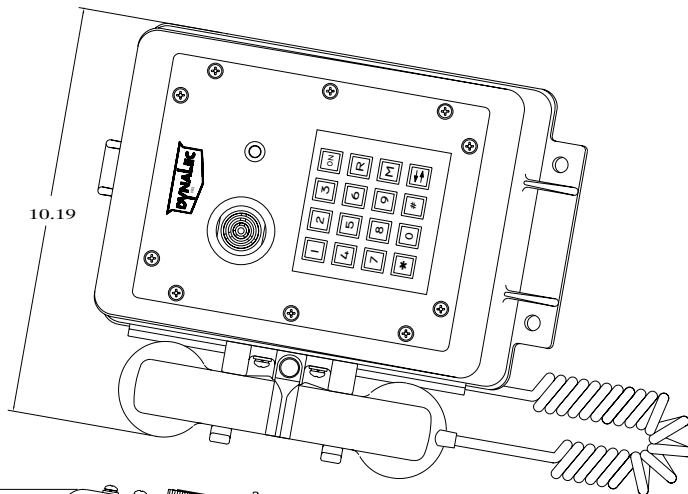

MATING CONNECTOR INFORMATION:

CONNECTOR	PART NUMBER	SIGNAL
J1	MS3106F20-29S	PBX IN AND POWER
J2	U-77/U	HANDSET OR HEADSET
J3	U-77/U	AUX. INTERCOM

POWER/LINE CONNECTOR (J1) PIN ASSIGNMENTS

PIN	SIGNAL
A	PHONE LINE : TIP
B	PHONE LINE : RING
C	POWER RETURN
D	POWER INPUT (-38 TO -56VDC)



87 WEST MAIN STREET
SODUS, NEW YORK 14551

Telephone
Fax
Internet

315-483-6925
315-483-6656
www.Dynalec.com

